

# Harvesting Machinery 2017



- 05 Rostselmash Globally
- 07 Customers about Rostselmash Machinery
- 09 Model Range
- 11 Power Stream Header
- 13 Comfort Cab II Cab
- 17 TORUM 780/750  
Powerful. Revolutionary. Rotary
- 19 RSM 161  
22 patents. Exclusive cleanliness of threshing
- 21 ACROS 595 Plus  
Special capabilities
- 23 ACROS 585/550  
Reliable Assistant at Every Farm
- 25 VECTOR 410  
Setting standard in the class
- 27 VECTOR 450 Track  
For Most Challenging Harvesting Conditions
- 29 Adaptors for Various Crops Harvesting
- 31 Optional equipment
- 33 Technical data



## ROSTSELMASH GROUP IS AMONG THE LEADING WORLD PRODUCERS OF AGRICULTURAL MACHINERY

2 Menzhinskogo str., Rostov-on-Don,  
Russia 344029

tel.: +7 (863) 255-20-43, 250-30-56  
Fax: +7 (863) 255-21-07

www.rostselmash.com  
market@oaorsm.ru



## ROSTSELMASH GLOBALLY

### RUSSIA

#### Rostov-on-Don Rostselmash

Manufactures Rostselmash grain and forage harvesters, VERSATILE tractors and sprayers.

#### Rostov-on-Don Klever

Manufactures adapters for combine harvesters, trailed and attached forage harvesting equipment, units for grain storage and processing, municipal machinery and snow clearing equipment.

#### Morozovsk, Rostov Region, Klever

manufactures adapters for combine harvesters as well as trailed and attached forage harvesting equipment.

### CANADA

#### Winnipeg VERSATILE

Manufactures VERSATILE 190 h.p. to 575 h.p. tractors. Here the central warehouse of VERSATILE spare parts is located.

#### Morden Farm King

Manufactures grain handlers, grain-cleaners, snowplows and compact tillage units. The central warehouse of Farm King spare parts.

#### Vegreville BUHLER EZEE-ON

Manufactures tillage and seeding equipment.

### USA

#### Salem Feterl Manufacturing Corp

Manufactures units for grain storage and processing, which are sold under the ROSTSELMASH brand in the Russian market.

#### Fargo Farm King

Manufactures bales transport trolleys, grader blades, wheel loaders, which are available under the ROSTSELMASH brand in the Russian market.

#### Villmar VERSATILE

Manufacture of trailed and self-propelled sprayers, which are offered under the VERSATILE brand in the global market.

### EXPERIENCE. INNOVATIONS. SUCCESS

For many years Rostselmash has been manufacturing agricultural machinery that sells well all around the world. Our expertise is based on extensive experience.

Today, Rostselmash comprises 13 companies located throughout the world, simultaneously aimed at the production of reliable and efficient equipment, capable of being the best assistant at every farm.

To date, Rostselmash can offer 24 types of agricultural and municipal machinery. Each client – from the owner of a small farm to the head of a large agricultural holding – can select the most effective equipment from more than 150 models and versions in our product range.

## ABSOLUTE EFFICIENCY FROM ROSTSELMASH

During its many years history, Rostselmash produced over 2,700,000 harvesters. Such experience allows us to offer now the most efficient agricultural machinery for harvesting, regardless of the type of crop and agro-climatic conditions.

Today, Rostselmash comprises 11 facilities in Russia, USA, Canada, Europe, Ukraine and Kazakhstan, which employ 11,000 people.

15 modifications of combine harvesters form 4 series - TORUM, RSM, ACROS, VECTOR. They are all united by one brand Rostselmash, which for decades has been synonymous with quality, reliability and efficiency.

That is why our combine harvesters work in the fields of more than 55 countries.

Year after year, our combine harvesters in different regions and on different continents show the highest results, raising the performance standard of agricultural machinery.

This became possible thanks to the company's innovative policy aimed at the use of modern equipment and technologies, as well as the manufacturing principles of the world industry leaders.

Rostselmash machinery is sold by more than hundred authorized dealerships providing the full pre-sales service of machinery, as well as its after-sales service.

Partnership with Rostselmash provides confidence that you obtain reliable and high-performance combine harvesters that can become indispensable assistants for every farm.



**TORUM 780/750**

Engine 506/425 hp  
Rotor Ø 762 mm, length 3 200 mm  
Concave angle, 360 degrees  
Cleaning 5.20 m<sup>2</sup>  
Tanker 12,000/10,500 l  
Unloading 105 l/sec



**RSM 161**

Engine 360 hp  
Drum Ø 800/750 mm, length 1 630 mm  
Separation 6 straw walkers, area 6.1 m<sup>2</sup>  
Cleaning 7.1 m<sup>2</sup>  
Tanker 10,500 l  
Unloading 115 l/sec



**ACROS 595 Plus**

Engine 325 hp  
Drum Ø 800 mm, length 1 480 mm  
Separation 5 straw walkers, area 6.3 m<sup>2</sup>  
Cleaning 5.20 m<sup>2</sup>  
Tanker 9,000 l  
Unloading 90 l/sec



**ACROS 585/550**

Engine 300/280 hp  
Drum Ø 800 mm, length 1 480 mm  
Separation 5 straw walkers, area 6.15 m<sup>2</sup>  
Cleaning 4.95 m<sup>2</sup>  
Tanker 9,000 l  
Unloading 90 l/sec



**VECTOR 450 Track**

Engine 255 hp  
Drum Ø 800 mm, length 1 180 mm  
Separation 4 straw walkers, area 5.0 m<sup>2</sup>  
Cleaning 3.59 m<sup>2</sup>  
Tanker 6,000 l  
Unloading 50 l/sec  
Caterpillar drive



**VECTOR 410**

Engine 210 hp  
Drum Ø 800 mm, length 1 180 mm  
Separation 4 straw walkers, area 5.0 m<sup>2</sup>  
Cleaning 3.59 m<sup>2</sup>  
Tanker 6,000 l  
Unloading 50 l/sec

## POWER STREAM HEADER

**Hydraulic-driven reel** ensures infinitely variable speed of rotation to achieve optimal and uniform supply of mass for improved performance. A simple and reliable mechanism with minimal adjustments.

**Single hydraulic jack** (multi-coupler) provides considerable time savings when connecting the header, ease of operation and protection against dirt.

**The cutter** operates smoothly, accurately and wear-free. High cutting speed and increased cutting strokes guarantee improve cut quality and, as a result, harvesting efficiency, especially in unfavourable conditions. Knives are bolted, which significantly reduces the replacement time. For cleaning of laid grain on uneven soils the crop lifters are used, which pre-lift stalks off the ground to reduce losses (included as standard).

**Large diameter of the auger** prevents the tall grains to be wrapped. Pins between the turns of the auger across the grip width allow moving the mass even with harvesting of peas and very low barley (for headers with electro-hydraulic adjustment). Pins have a groove for accurate chipping when in contacts stones.

**The system of synchronisation** of the reel rotation speed and a combine harvester ground speed makes the operator work easier, lowers requirements to its qualification. As a result, improved harvesting efficiency and decreased losses. The joints of beams of the reel and tines are protected from long-stalk plants wrapping.

**Cooling Chamber**

A cool drink is always very close, at hand.

**Healthy Microclimate**

With the climate system, numerous air vents and a sun screen one can easily create a favourable microclimate.

**Large Panoramic Glass**

A considerable glass area (more than 5m<sup>2</sup>) and panoramic glasses guarantee free all-around view.

**ADVISER III Display**

A colour touch display (10") not only ensures control of the process of threshing and state of functional systems, but is also used to make settings of the machine.

**16-Function Manipulator**

The handle on the Hydrostatic Power Transmission lever is a key element of the combine harvester control.

**Adjustable Steering Column**

A steering column with a double bend and adjustable height allows to set the working place as needed.

**Audio fittings**

Favourite music can help to relieve the busy shift. A mounting seat is provided for a car-stereo. The sound system and an aerial are included in the basic package of the cab.

**Comfortable Chair**

The spring-mounted chair with 5 settings allows choosing a comfortable operating position and fully focusing on harvesting.

**Armrest**

The right armrest is equipped with a built-in console with all the essential functions of operation control.

Improved noise and vibration insulation, fully updated controls, stylish interior and high quality materials - Comfort Cab II offers a new level of comfort in the workplace!



- 1 – header control (lifting/ lowering, left/right tilt)
- 2 – auger setting-out/folding
- 3 – grain tanker unloading on/off
- 4 – emergency stop
- 5 – automatic system on/off
- 6 – saving and selection of the gauging system operation mode
- 7 – reel control (lifting/ lowering, setting-out/retraction)

- A – header on/off
- B – thresher on/off
- C – navigation keys
- D – engine speed control (3 levels)
- E – feed house reverse
- F – reel, threshing drum and separator fan speed control, and the concave clearance control
- G – screens clearance control
- H – tanker roof control, incl. hydropulsator
- I – parking brake

All functions of the combine harvester requiring immediate reaction are concentrated at the operator's right hand.

The remote control with basic and frequently used controls is built into the armrest, and moves together with the chair.

# TORUM 780/750

POWERFUL. REVOLUTIONARY. ROTARY

TORUM is a powerful rotary grain combine harvester, among the most high-performing in the world. The range of harvested crops is wide — from wheat to rice. This combine harvester is a good choice for farms with large crop areas and high yield: the more machinery is loaded, the more efficiently it operates. Thanks to the innovative threshing system ARS\* TORUM perfectly copes with grains, which present difficulty for conventional rotary combine harvesters.

\* Advanced Rotor System - beater feeder, rotor with the rotating deck, infinitely variable speed rotor drive.



## NEW ECONOMICAL ENGINES

TORUM is equipped with two options of economical MTU engines - 425 and 506 hp six-cylinder in-line OM 460 LA series. These engines have excellent performance by specific fuel consumption and torque reserve. The air cleaning system uses air intake mesh with forced rotation (from the hydraulic motor), which significantly reduces the complexity of maintenance.

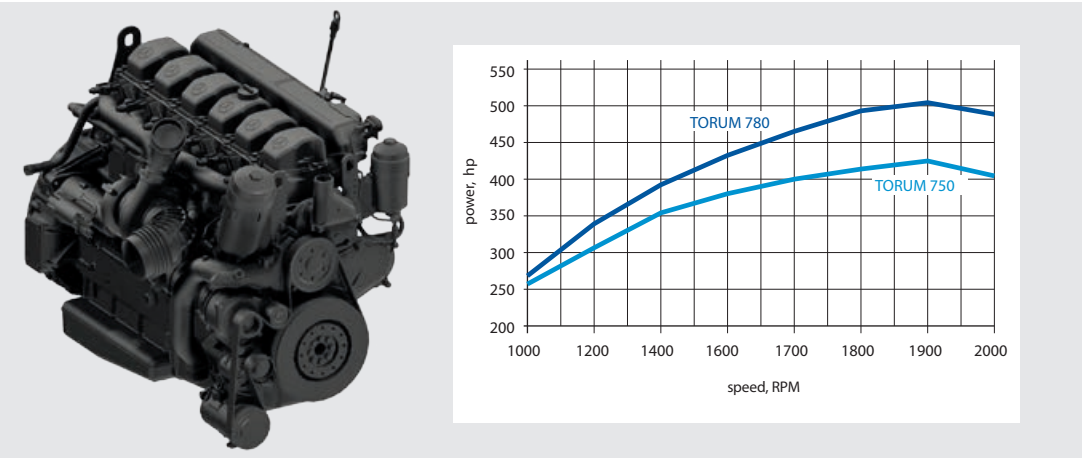

## ADVANCED BEATER FEEDER

The uniqueness of the feeder is that the traditional chain-and-slat transporter is replaced by three feed beaters with special elements. This would greatly improve the stability of the process and, as a consequence, increase the performance of the combine harvester. Beaters of the feeder spread

and accelerate the mass in front of the rotor ensuring a stable process. Studies showed that, as compared with conventional slatted conveyors beaters increase the capacity of the feeder by 20%, while the power consumption is reduced by 15%. This scheme is especially effective when working on uneven rolls, with high humidity and debris population of the mass, with rice and other harsh conditions.

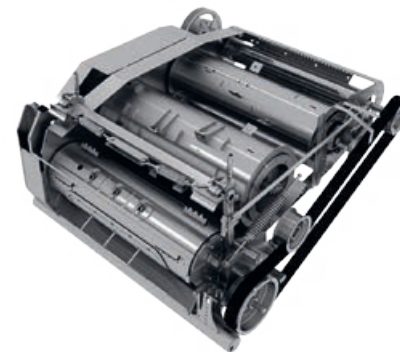

## MAXIMUM CLEAN

The two-section cleaning system with work area of 5.2 m<sup>2</sup> is in line with outstanding features of the rotor. The system is well-balanced: the agitator board and the lower screen move in one direction, and the massive part of the upper screen - in the opposite direction. The powerful two-section fan with the hydraulic drive generates uniform air flow through the fan mesh and prevents dead zones emergence, as air intake is produced not only out of ends, but out of the middle, too. Thus, it secures the really clean grain.

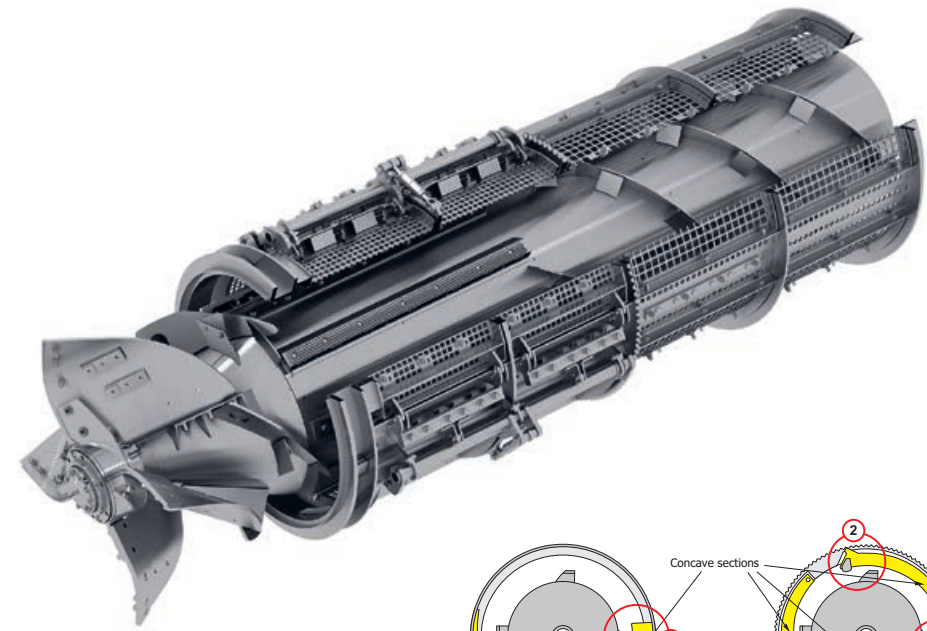
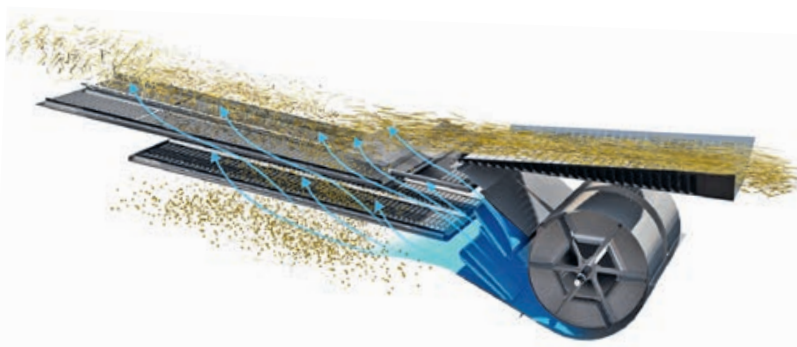

## UNIQUE 3-POINT THRESHING SYSTEM

The concave has three threshing sections allowing to set a threshing gap in one section. Thanks to this the mass is threshed three times with one round of the rotor unlike the single threshing in conventional rotor units.

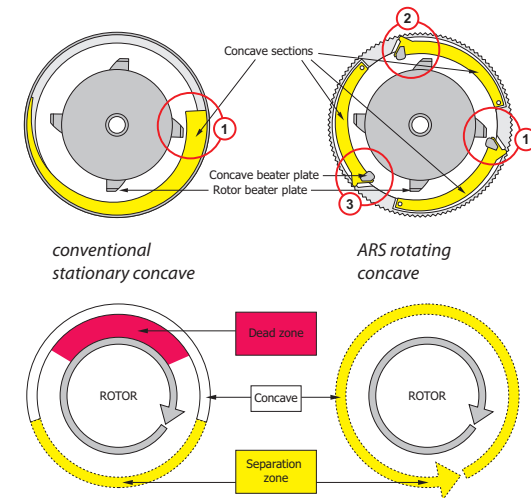

## FASTER, HIGHER, MORE

Clean grain goes into the tanker with capacity of 10,500 liter (TORUM 780 - 12,000 liters). Such capacity increases performance efficiency by reducing unload cycles. The unloading rate is 105 l/sec, the entire tanker is discharged within 2 minutes. The unloader auger has sufficient dimensions to fit any vehicle. The convertible roof, fill level sensors, hydropulsators and other features provide additional convenience and increase operation efficiency.



**Up to the last grain:** Before getting into the shredder, the straw mass undergoes a final separation through the drum with the grate-type concave installed at the rotor output.

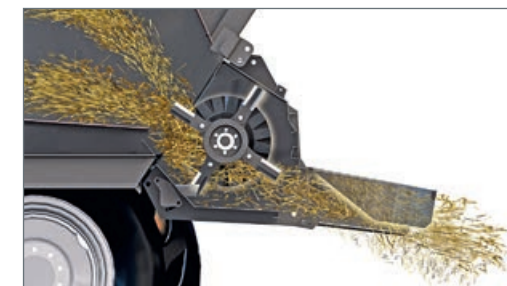

**Shredder with integrated chaff spreader.** Through combining chaff and straw flows uniform spreading of the shredded mass across the field is achieved.



## High quality of straw.

The separating part of the rotor has the auger-type winding. Due to this, TORUM unlike conventional rotary combine harvesters treats straw more or less delicately.

## ROTATING CONCAVE

Rotation of the concave provides its self-cleaning, guarantees no «dead» zones in the gap, prevents mass stoppage and clogging of the rotor. In addition, energy consumption during the threshing process is reduced by 8-10%.

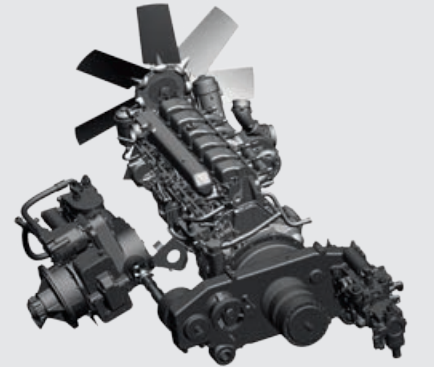

## INFINITELY VARIABLE ROTOR SPEED

The rotor is driven by the planetary CVT with hydraulic control - a unique hydro-mechanical device, which combines the advantages of both types of drives: smooth and accurate speed control, high bearing force and reliable beltless transmission.



# RSM 161

## 22 PATENTS. EXCLUSIVE CLEANLINESS OF THRESHING

RSM 161 harvester is designed for harvesting all traditional grain crops — spiked cereals, bean cultures, oil plants, cereal and arable crops. Efficient machinery with productivity of approx. 45 t/h makes it possible to process up to 2,000 ha per season.



## POWERFUL AND FUEL-EFFICIENT CUMMINS ENGINE - 360-380 H.P.

RSM 161 is equipped with powerful and fuel-efficient 6-cylinder engine Cummins QSL8.9, L6, 380-380 h. p., St-III A (Tier VI f). A large torque reserve (25%), simple design, low maintenance costs coupled with high fuel efficiency.



## HIGH-CAPACITY FEEDERHOUSE

A new gen feeder house with an accelerating output beater features a single hydraulic coupling, adjustable angle for higher performance and ease of harvesting of any crops without making any modifications, with quick adapters connections (headers of 4 500 kg mass).

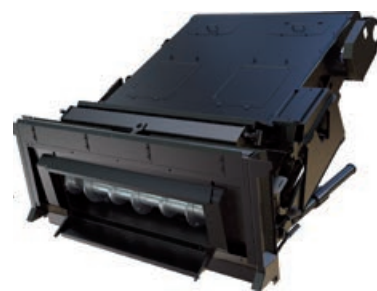

## CABINE LUXURY CAB WITH INFORMATION SYSTEM ADVISER III

RSM 161 harvesters are provided with the new cabin Luxury Cab. As soon as you get inside you will feel how comfortable the operator station can be, and you will be pleased with the comfort that really adds to performance efficiency, less strain and fatigue. The Adviser III voice information system continuously monitors the threshing process and the functioning of harvester mechanisms, and allows to monitor the process stability and prevent the failure of units.



## OPTIFLOW EFFICIENT CLEANING SYSTEM

For material cleaning, an OptiFlow double cascade cleaning system is used, which features a proprietary suspension for sieves with an area of 7.1sq.m. A powerful optimized air flow, large drop height and pre-cleaner tine grid significantly improve cleaning performance. The chaffer uses the 'wave' sieve technology - fishbacks are of different sizes. This proprietary solution ensures a more uniform distribution of the air flow and prevents sticking of highly bearded heads in the sieves. The cleaning system utilizes double flow turbofan with electrically controlled louvers; fan speed is controlled from the cab and displayed on the control panel. Cleaning of sieves and components is easy, the sieves can be quickly adjusted by the operator from the cab.



## STRAW WALKERS WITH LARGE SEPARATION AREA

6 efficient walkers providing an overall area of 6.1 sq.m and autonomous rethreshing unit will see to it that crops are harvested with minimal loss. The shaking amplitude of sections is designed to ensure the maximum degree of separation of grain from heaps.



## TETRA PROCESSOR THRESHING SYSTEM

The Tetra Processor system features a flexible deck with automated electronic control of the gaps along whole length. Huge area of threshing and separation of 3.3 sq. km (in total 9.4 sq. km) provides intensive separation process with minimum damage to grains and straw, even in the most complicated soil conditions. The Tetra Processor threshing system is built using the drum of 800 mm diameter, providing stable and delicate threshing without losses. 750 mm diameter separator facilitates transfer of the grain mass along smooth pathway. 1 650 mm of width allows for a combine capacity of 45 tons per hour.

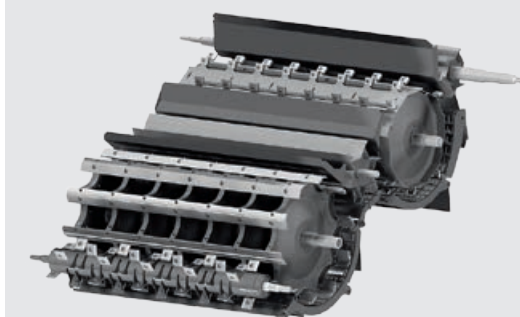

## FAST UNLOADING

Large-capacity grain tank with advanced scheme of unloading into vehicles with side height over 4 m, and with the vibration agitators. Tank volume of 10,500 L allows to increase performance efficiency by reducing unload cycles. Unload rate is 115 L/sec, it takes 2 minutes to empty a full tank. The grain can be easily unloaded into any trucks and trailers, while using a header with a width up to 12 m, when harvesting rice unloading can be done without leaving the bay. For fuel efficiency, the thresher drive can be disengaged.



## STRAW CHOPPER/SPREADER

2-speed chopper/spreader improves the feeding of straw to swath. It can effectively handle grain and tilled crops, with activation from the cab. A large number of knives and counter knives ensure high quality chopping. Adjustment of straw spreading width from the cab possible (optional). Standard version of the harvester is equipped with chaff spreader.



# ACROS 595 Plus

## SPECIAL OPPORTUNITIES

Over the years, ACROS harvesters proved to be efficient and able to show truly phenomenal results. What could be improved in these machines? In the new model its designers focused on behaviour of the combine harvester in tough conditions for all 1-drum combine harvesters. ACROS 595 Plus is ideal for farms located in regions with high yields, humidity and straw availability.



## SPREAD AND ACCELERATE THE GRAIN MASS

Accelerating beater is installed in the feeder house of ACROS 595 Plus. Due to this, the combine harvester obtained some operational advantages. The accelerating beater perfectly spreads and accelerates the grain mass before feeding it into the threshing drum, thereby reducing the load on the thresher and increasing its capacity. With the absence of the receiving beater there is no need to convert the feeder for harvesting tilled crops.



## FOLLOWING THE FIELD RELIEF

The ACROS 595 Plus basic package includes automatic system of soil relief following, which improves the harvesting efficiency due to increase of the working rate and reduce losses behind the header. Three modes of operation, automatic transition of the adapter into the transport position and programmable gauging presets simplify the harvesting process. Electronics will take care of the challenging relief.

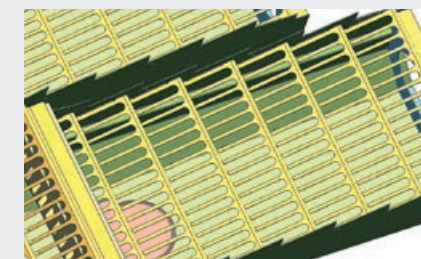

## CAREFUL SEPARATION IN ANY CONDITIONS

The new ACROS 595 Plus straw walker provides more intensive separation process, especially in high humidity conditions. The area of separation increased due to longer racks. The rack grooves are cut lengthwise to guarantee better grain spillage.

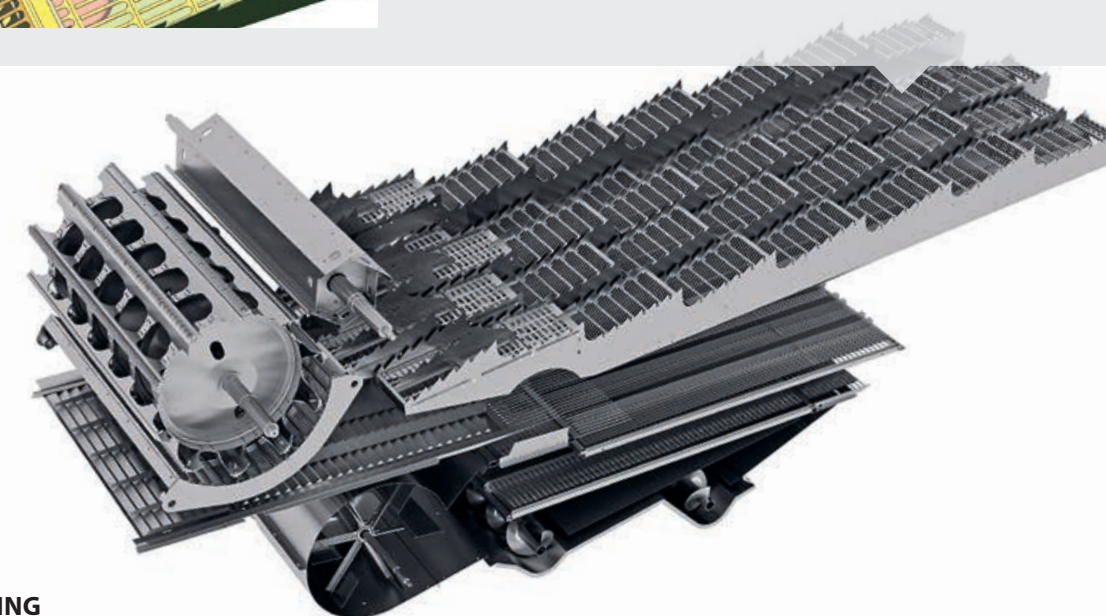

## TWO-STAGE CLEANING

ACROS 595 Plus received an absolutely new cleaning system. An additional screen forms a second ventilated stage, a high-performing 2-section fan produces a more powerful air flow, the total screen area reaches 5.2 m<sup>2</sup>. All this guarantees feeding of grain that does not require additional cleaning to the tanker.



## UNIFORM CHAFF SPREADING ACROSS THE FIELD

A chaff spreader can be additionally mounted on ACROS 595 Plus. It provides the uniform chaff spread across the header width, which is a required condition for subsequent plowless tillage. The chaff spreader rotor speed can be controlled both from the cab and from the outside, and the hydraulic drive does not require any additional settings and adjustments.

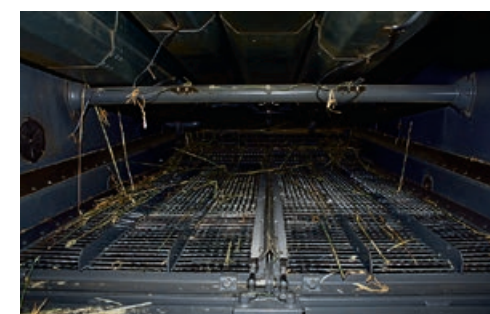

**Electrical adjustment of the screens** allows making all cleaning settings quickly and conveniently without leaving the workplace. This makes it possible to reduce ineffective working time and losses. This option becomes particularly important in changing harvesting conditions.



**The new shredder** of straw works under the improved scheme "laying the swath along the movement direction". The new changes to the design have improved the shredding level and spreading width, as well as eliminated the risk of arching of the heap of straw, in particular, long and tangled stalks of buckwheat or rape.



**Protection of grain against moisture**  
The new tanker design with door opening lengthwise made access to the tanker for maintenance more convenient and safer. The design provides for a special apron that will reliably protect the grain from moisture ingress and blowing away in the case of small-seeded crops harvesting.

# ACROS 585/550

## RELIABLE ASSISTANT AT EVERY FARM

ACROS is ideal on fields with high and medium crop yield. The basis of the combine harvester is the proven threshing and separating device with single large drum (800 mm) and a key-type straw walker. The exceptional performance of the machine is achieved due to the high output per shift, reliability and streamlined service.



### SMART LAUNCH

Smart Launch is a patented device of independent consecutive start of the unloading and horizontal augers. Such device easily guarantees high-speed unloading with minimum risk of clogging. In addition, thanks to Smart Launch the combine harvester allows unloading by portions. And these are far from all useful features of the system. Another one is that when you turn off the unloading auger it is always freed from the remnants of grain to avoid the loss of grain during the auger folding, which is quite typical of many other combine harvesters. Thus, Smart Launch increases the efficiency of clearing the tanker making the process quick, convenient and less labour consuming.

### SAVING TIME FOR UNLOADING

As practice shows, at least 5% of the working shift is spent on the unloading of grain. In order to reduce this time ACROS uses a high-performing unloading device (unloading rate up to 90 l/sec.) and a high-capacity tanker (9,000 liters). Particular attention is paid to work in high humidity conditions. Hydropulsators installed at the bottom of the tanker allow unloading grain with humidity up to 35%. Level sensor will provide unprecedented control and «advise» optimal unloading time. Height, length and turning angle of the unloading auger are designed to perform seamless uploading to any freight vehicle, even if it is a long trailer, and the combine harvester is equipped with a header of 9 meters wide. A possibility to switch off the thresher engine during unloading reduces fuel consumption and saves the thresher life.



### MAXIMUM PERFORMANCE

Traditional threshing system implemented in the combine harvester is rightfully considered as ACROS's strength. A classic single-drum thresher is objectively the best combination of high capacity and low power consumption. In addition, it features the minimum risk of grain damage and delicate handling of straw.

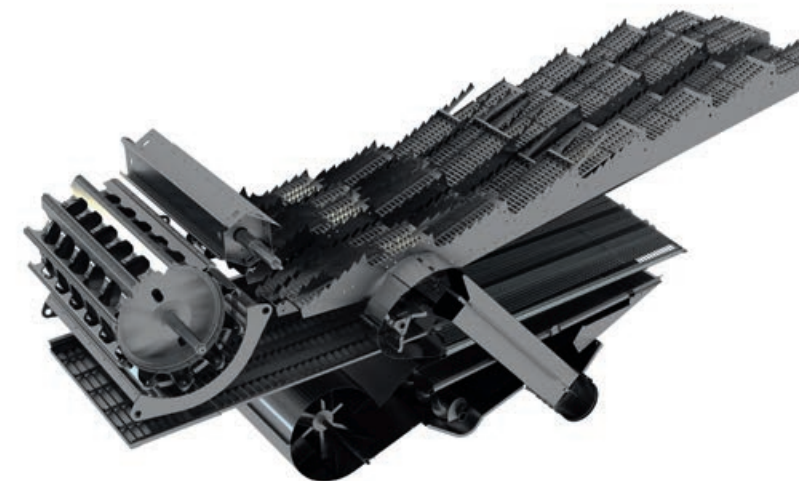

### NEW SCREENS

The updated design of the screens features the increased cleaning area up to 4,95 sq.m. Besides, the upper and lower screens are separated into left and right sections for maintenance convenience.

### MAXIMUM AMOUNT OF GRAIN, MINIMUM AMOUNT OF CRUSHED GRAIN

Spikes left after threshing are supplied to the standalone final threshing device, then the recovered grain is distributed over the entire width of the agitator board. Through this the complete cleaning cycle is achieved with no risk to overload the screens. The device features a 3-blade rotor, which as compared to final threshing devices guarantees more smooth threshing and reduces crushing.



### OPTIMAL POWER

The new power of ACROS is provided by YaMZ (280 h.p.) and Cummins (300 h.p.) engines. They are simple and easy to maintain, and have long between maintenance periods.

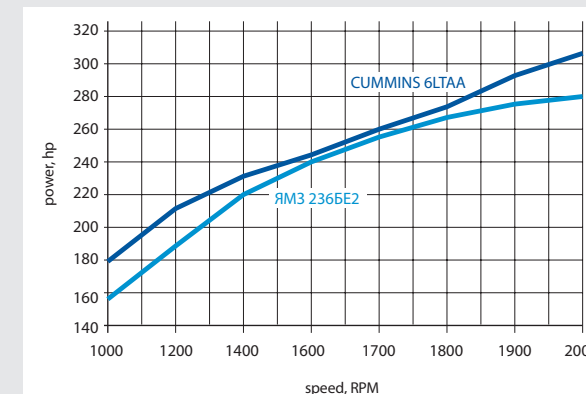

The new **extended feeder** has several advantages: a better view of the cutting device, more simple operation for harvesting tilled crops due to the absence of the receiving beater, and a possibility to work with wide angle adapters (for example, conveyor header Draper Stream 900).



**Two shredding speeds.** The shredding drum has two rotating speeds: 3 400 RPM for grain harvesting, and about 2 000 RPM for corn. A lower speed is introduced to reduce the wear of the shredder parts.



**The air compressor** saves a lot of time for monthly maintenance, especially in the field, when the technical support car is not available. The compressor is included in the basic package as Rostselmash introduces new industry standards.

# VECTOR 410

## THE STANDARD IN ITS CLASS

VECTOR is the most efficient solution for harvesting fields with low and medium crop yield. With seasonal run of 500-800 ha without tilled crops, optimal owner cost and fuel efficiency this combine harvester is the most practical choice for farms.

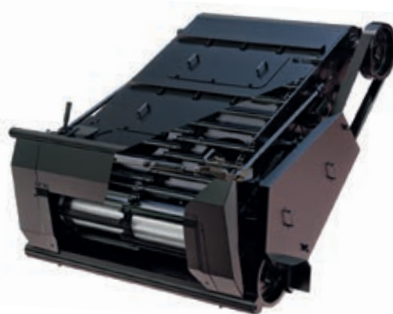

### The new extended feeder

has several advantages: a better view of the cutting device, more simple operation for harvesting tilled crops due to the absence of the receiving beater, and a possibility to work with wide angle adapters (special design of the harvester allows to work with adapters of 3 000 kg in weight, for instance - with conveyor header Draper Stream 900).

**Solid character.** VECTOR received a solid and reliable single-drum classical scheme with a unique feature of Rostselmash combine harvesters - the drum with the largest diameter in the world (800 mm). This device has a lot of advantages. Among the main ones are high capacity and delicate separation meeting the strictest requirements to grain quality. But still the main advantage of the VECTOR single-drum scheme is simplicity in dealing with challenging grains.

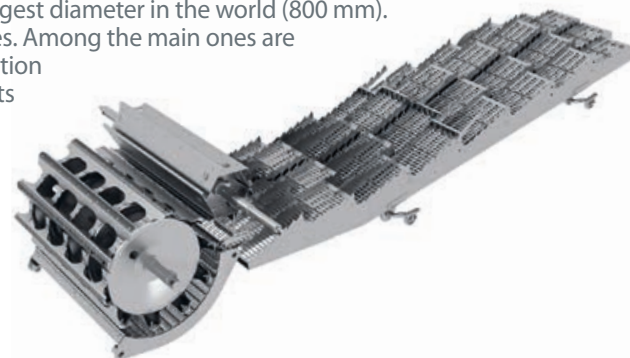

**The air compressor** is included into standard version. Thus, harvester's independence of maintenance machine is guaranteed, at that increasing shift capacity by more than 10%.



**Non-stop.** The Jam Control deep drop device will help to eliminate jamming without stopping the threshing drum. Control from the cab helps to save the working time, without spending it on redundant operations.



**Control the tanker from the cab.** The convertible roof of the device, if necessary, allows increasing its volume from 4.5 m<sup>3</sup> to 6 m<sup>3</sup> or decrease vertical dimensions of the combine harvester. The electrical opening mechanism is controlled from the cab. The tanker is equipped with hydropulsators installed on the bottom - a distinguishing feature of Rostselmash combine harvesters. Thanks to them, the combine harvester easily copes with unloading of wet grain, which leads to increase in output per shift.



**Flexible straw handling.** An important advantage of the VECTOR combine harvester is that only it in its class can offer such a variety of schemes of work with the non-grain part of the harvest. Straw cannot only be shredded, spread or put to the crushing barrel (crusher). A 12m<sup>3</sup> stacker comes as an option for VECTOR. It can gather straw in stacks unloading them automatically.

# VECTOR 450 Track

FOR MOST CHALLENGING HARVESTING CONDITIONS

VECTOR 450 Track is the grain harvester designed specially for harvesting in challenging soil conditions. Its distinguishing feature is caterpillar chassis. Thanks to the huge contact area, this combine harvester is, perhaps, the only acceptable solution for the marshy fields that are common, for example, in the Russian Far East, as well as in rice-growing regions.



## COMFORT AND IDEAL FOLLOWING THE FIELD RELIEF

Through the use in the caterpillar truck of independent suspension rollers and uniform weight distribution, VECTOR 450 Track moves smoothly across the field, the header remains practically stationary and only follows the field relief. This is an important condition of complete harvesting, especially low hanging soy beans. And, of course, the operator will fully enjoy the highly comfortable driving.

## COMFORT DRIVING

Driving the combine harvester does not differ from driving a wheeled vehicle, it has the usual steering wheel and hydraulic transmission lever.



## POWERFUL ENGINE WITH PRE-HEATING

The high-power 255 h.p. engine is equipped with the air compressor and pre-heating starting device.

## CONFIDENT ROAD MOVEMENT

The use of steel cord crawler belts means minimal wear when working in dry conditions and a possibility of comfortable movement on paved roads.



## ADAPTORS FOR VARIOUS CROPS HARVESTING



### Maize

For corn harvesting for grain, 6-, 8- or 12-row headers that are used to guarantee performance up to 6 ha/h. It should be noted that this device crushes and scatters leafy mass on the field.



### Rice

When harvesting rice, a quality cut of its tangled and stiff stalks is achieved by a rackless header with a double cutter and a special visor on the table. This set which is easy to install will increase the working speed and lower the risk of jamming the header.



### Rape

When harvesting easy-to-damage crops, optional equipment is offered in order to provide maximum efficiency. Rape harvesting attachment for headers for 5/6/7/9 m will reduce losses during cutting by 3 - 4 times and additionally collect, depending on the crop yield, 30 - 100 kg of grain from 1 ha of crops.



### Soybean

Losses during harvesting of soy beans and other crawling crops decline sharply, if we use the header with a flexible cutterbar capable of following the field microrelief. The header coverage is from 5 to 9 m. Rigid fixing of the knife is provided for harvesting traditional upright standing crops.



### Sunflower

Specially designed for sunflower harvesting 8- and 12-row headers ensure complete harvesting of at least 99%, which is not achievable with other types of devices. Headers reliably operate in any agricultural environment, including low height sunflower hybrids.



### Grain and oil-bearing crops

Increasing productivity by 10-15%, especially during harvesting of undersized, low-yield and oil-bearing crops can be achieved through the use of draper headers (in two versions - for harvesting grain and oil-bearing crops).



### Swath pick up

During separate harvesting the combine harvesters are equipped with the platform 3.4 or 4.3 m wide. As the header, this device can follow the field relief in the longitudinal and transverse directions. Reliable protection of the crop collector elements from jamming, wrapping and blowing away of the mass by the wind ensures its stable operation even in adverse conditions.

## EQUIPMENT FOR HARVESTING VARIOUS CROPS

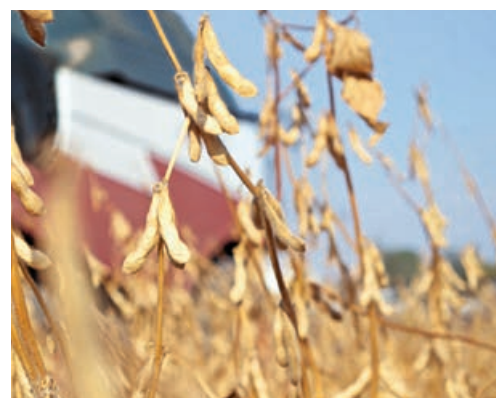

### Easy-to-Damage Crops

Threshing cereals and oilseeds, which grains are easily damaged, it is necessary to work with a low speed of the threshing unit. This is also provided for in Rostselmash grain harvesters. The list of the optional equipment for machinery includes reduction gearbox built-in in the drum. This device is designed to guarantee delicate threshing with a minimum percentage of damaged grain.

### Small-seeded crops

When harvesting the seed plots of beans and grasses, losses can be significantly reduced and the seed purity can be increased, if the combine harvester will be equipped with a special device («punch» screens, concave strip, etc.).



### Harvesting on damp and marshy soils

Working in the fields with waterlogged soil will require additional equipment that can ensure the combine harvester steady movement even in the toughest conditions. Rostselmash harvesting equipment instead of wheels on the front axle uses semitracks, in addition to this, steered rear wheels can be equipped with the drive.

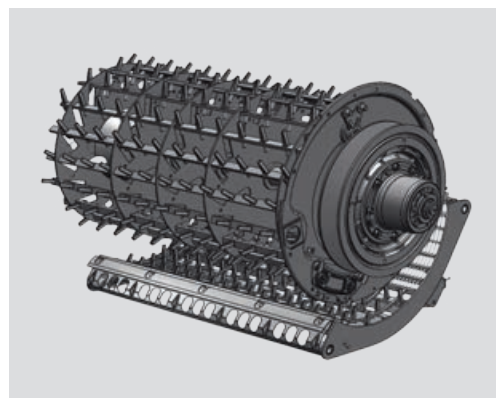

### Rice

TORUM - the leader in rice harvesting. The ARS rotor system, designed for harvesting this challenging crop, is only supplemented by elements from the «rice» kit. Many varieties of rice can be harvested by the VECTOR combine harvester, in which the standard threshing drum and the concave are replaced with special pinned ones.

### Undersized and thinned out crops

A special set of header spare parts is offered for efficient harvesting of undersized and thinned out crops.

## OPTIONAL EQUIPMENT



### Yield mapping system

The precision farming is based on the principle of knowing one's field to the smallest spike. Implementation of resource saving technologies is impossible without crop yield and humidity mapping system.



### System of control of grain return for rethreshing

Shows the level of mass going for final threshing. Helps to correctly set the threshing and separating device for efficient operation.



### Navigation and auto-piloting

The use of satellite system of auto-piloting reduces the header overlap zone and reduces an operator's fatigue.



### Towing attachment

The main advantages of a universal towing attachment with the catcher is quick assembly and disassembly of the cart.



### Video System

The wide-angle camera will facilitate manoeuvring, unloading and control of spreading crushed residue.



### Fuel consumption monitoring system

The fuel flow monitoring system helps to prevent overspending and fuel drain, and to keep accurate accounting and cost planning.



### Lubrication system

The centralized lubrication system will not only reduce maintenance time by several times, but will also increase the life of critical assemblies.



### Printer

With the onboard printer you can print out performance indicators of the combine harvester and other useful information, such as the maintenance schedule.



### Spreading angle adjustment

Included in the optional equipment list, the shredder deflector electrical adjustment immediately from the cabin is particularly useful during the combine harvester operation on slopes or during windy weather.

		TORUM 780	TORUM 750	RSM 161	ACROS 595 Plus	ACROS 585	ACROS 550	VECTOR 450Track	VECTOR 410
<b>Header unit</b>									
POWER STREAM Header	–	●		●	●	●		●	
Header coverage	–	6,0/7,0/9,0		7,0/9,0	5,0/6,0/7,0/9,0	5,0/6,0/7,0/9,0		5,0/6,0/7,0/9,0	
Cutting unit drive based on planetary gear reducer	–	●			●	●		●	
Automatic synchronisation of the reel rotation speed and a combine harvester speed	–	●			●	●		●	
Crop lifters	–	○			○	○		○	
Trailer	–	○			○	○		○	
<b>Feeding</b>									
Feeder type	–	beaters		conveyor and acceleration beater		conveyor		conveyor	
Relief copying spring system	–	–		–		●		●	
Relief copying electrical and hydraulic system	–	●		●		–		–	
Single hydraulic connector (multi-coupler)	–	●		●		●		●	
<b>Threshing</b>									
Thresher type	–	rotary with rotating concave		2 of drum	1 of drum	1 of drum		1 of drum	
Drum/rotor diameter	mm	762		800/750	800	800		800	
Drum/rotor length	mm	3 200		1 630	1 480	1 480		1 180	
Concave/ rotor concave coverage	deg.	360		124	130	130		130	
Overall concave area (threshing and separating part of rotor)	m <sup>2</sup>	5,40		3,3	1,38	1,38		1,1	
Drum/rotor speed (with reduction gearbox)	RPM	250–1 000		300–920	335–1 050 (200–450)	335–1 050 (200–450)		335–1 050 (200–450)	
Jam Control module	–	–			●	●		●	
<b>Separation</b>									
Number of the straw-walker racks	pcs	–		6	5	5		4	
Length of the straw-walker racks	mm	–		3 500	4 100	4 100		4 100	
Straw-walker separation area	m <sup>2</sup>	–		6,1	6,3	6,15		5,0	
<b>Cleaning shoe</b>									
Cleaning system type	–	3-screen (2 stages)		3-screen (2 stages)		2-screen, sectional		2-screen	
Overall area of screens	m <sup>2</sup>	5,2		7,1	5,2	4,95		3,59	
In-cab electrical adjustment of sieves	–	●		●		–		–	
Final threshing device	–	stand alone		stand alone		stand alone		stand alone	
<b>Grain tank</b>									
Tanker capacity	liters	12 000	10 500	10 500	9 000	9 000		6 000	
Discharge rate	L/sec	105		115	90	90		50	
Discharge height	m	5,4	5,2	5,05	4,3/4,7	4,3/4,7		3,48	3,48
Hydropulsators		●		●	●	●		●	
Independent discharge (by portions, in any position of the unloading auger)		+		+	+ Smart Launch	+ Smart Launch		–	
Waterproof tanker		–		–	●	●	–	–	
<b>Processing of the non-grain part of the harvest</b>									
Shredding drum speed	RPM	1 600 / 3 400		1 900 / 3 400	1 800 / 3 400	1 800 / 3 400		2 900	
Number of knives	pcs	76		64	76	76		60	
Spread angle adjustment from the cab		●	○	○	–	–		–	
Chaff spreader		built-in in the shredder			●	–		–	
Harvester stacker		–		–	–	–		–	○ 12,0 m <sup>3</sup>
<b>Cab</b>									
Luxury Cab with the system Adviser III		–		●	–	–		–	
Package Comfort Cab with Adviser II system		–		–	–	–	●	●	
Package Comfort Cab II with Adviser III system		●		–	●	●	–	–	
Automatic driving system		○		○	○	○		○	
Yield and moisture mapping system		○		○	○	○		○	
Unloading zone video monitoring system and back monitor		○		○	–	–		–	
Automatic centralised lubrication system	–	○		○	○	○		○	
<b>Undercarriage</b>									
Transmission		hydrostat.		hydrostat.	hydrostat.	hydrostat.		hydrostat.(2)	hydrostat.
Wheelbase	mm	3 817		3 800	4 000	4 000		4 100	3 778
Drive wheels track	mm	3 120		2 900	3 100	3 100		3 200	2 845
Driving wheel tyre type		900/60R32	30.5LR32		30,5LR32		30,5LR32		28LR26
Steering wheel tyre type		500/70R24	540/70R24		18,4R24		18,4R24		18,4R24
Removable half-tracks		○		○	–	–		○	
All-wheel drive		○		○	–	–		○	
<b>Engine</b>									
Manufacturer/grade		MTU/OM460LA		Cummins/QSL8.9	Cummins/6LTAA	Cummins/6LTAA	YaMZ/236BE2	YaMZ/236BK	YaMZ/236ND
Engine capacity, no of cylinders, arrangement	liters	12,82l / L6		8,9 L6	8,9 L6	8,9 L6	11,0 V6	11,0V6	11,0V6
Power	kW/h.p.	372 / 506	313 / 425	279 (360–380)	239 / 325	221 / 300	206 / 280	188 / 255	154 / 210
Fuel tank capacity	liters	850		1 050	540	540		540	540
Fuel consumption monitoring system		●		●	–	–	○	○	○
Air compressor		●		●	●	●	●	●	○
<b>Overall dimensions and weight</b>									
Length/width/height (without header, in transportation position)	mm	8 931/3 677/3 950		9 250/3 675/3 940	8 850/3 880/3 940	8 846/3 880/3 940		7 940/3 900/4 000	8 557/3 560/4 015
Weight (standard model with shredder, without header and fuel)	kg	16 350		16 500	14 330	13 400		16 600	11 390

● standard ○ optional – not available